

# METAL FABRICATION

## SCOPE

This specification applies to all metal intended to be rubber lined. Metals furnished must conform to this specification with respect to suitability for rubber lining or covering.

## MATERIAL

- a. The surfaces are to be free of galvanizing or other plating, oil and grease. The surface must also be free of scale and other foreign material not readily removed by sandblast or shotblast. Castings, when specified, are to be smooth and free of porosity, defects, sand or blow holes and other such imperfections.
- b. All plates shall be flat, with no appreciable buckle or warpage. Sharp edges must be removed; burrs are not permissible. The thickness and weight per square foot shall be no less than the figures listed below:

THICKNESS	WEIGHT PER FOOT
7/64"	4.375
9/64"	5.625
3/16"	7.50
1/4"	10.2
5/16"	12.5
3/8"	15.0
1/2"	20.0

- c. Pipe is to be standard weight, new welded or seamless steel to ASA schedule 30 to 40 unless otherwise specified. Wall gauge to be specified if not shown or called for on purchase order or drawings.
- d. Flanges shall be flat faced, not raised, standard 150# forged steel slip-on, weld neck or boiler plate. 125# cast iron flanges or cast iron pipe - are not recommended for rubber lining. If customer insists - they do so at their own risk.
- e. Flanges on opposite ends of pipe are to have their bolt holes in exact alignment unless otherwise specified. Pipe ends at flange face are to be continuously welded and ground smooth. Rough burrs should be removed.
- f. When cast steel domes and fittings are specified, they shall be free from porosity, sand holes and other foreign material.

### DIMENSIONS

Unless otherwise specified, dimensions for vessels are considered inside dimensions, for pipe, overall length end to end and for projecting fittings from outside of vessel surface to face of fitting, nozzle or flange.

Tolerances shown below apply to individual parts and to overall dimensions when parts are made up from sections, when such tolerances are specified on the drawings.

Straight Pipe 24" or less	Plus or minus 1/16"
Straight Pipe over 24"	Plus or minus 1/8"
Other dimensions	Plus or minus 1/8"

### CONSTRUCTION

- a. Drawings that are attached to and are a part of the purchase order should prescribe requirements of metals to be rubber lined or covered. Materials shall be fabricated in accordance with good commercial practice.
- b. All vessels shall be constructed with a minimum number of pieces. Rectangular tanks of the open top type shall be properly reinforced in accordance with accepted practice to provide adequate structural strength and to prevent bulging. Normally, a drawing or definite information showing required reinforcement will be furnished.
- c. Companion angles of sectional vessels that are bolted together must be square, plumb and smooth with sections fitting exactly when bolted together. (Specified rubber thickness to be allowed in fabrication should such companion angles require rubber). The open ends of sectional vessels shall be provided with suitable bracing so that they will not become distorted in transit and handling. Sectional vessels shall be permanently match-marked on spots that are not to be rubber covered to accurately indicate their position when assembled.
- d. Unless otherwise specified, the necessary bolts, nuts and washers to complete any assembly are to be furnished by the metal supplier or fabricator.
- e. Vessels with dished heads are to have the dished heads flanged in such a manner as to eliminate wrinkles and buckles.
- f. Vessels subject to more than 10# working pressure must, when practical, have heads dished from one-piece plates. When, from necessity, heads are made up in sections, the sections are to be formed before welding together and must be of 20% greater thickness than specified for the one-piece head. Welds on sectional heads shall be made according to Paragraph U-659 of the ASME code procedure latest revisions or addendum. Plate thickness of heads shown on drawings or orders are for one-piece heads.
- g. All exterior corners or angles to be rubber covered shall be radiused to 1/8" minimum.
- h. Fabrication Procedures for Continuous Pickle Lines
  - I. Mate and match-mark each adjoining tank section that is to be welded in the field.
  - II. When several like flue covers are involved, a master template should be made to drill both flue covers and tanks. When only a few flue covers are involved, the flue cover should be drilled and the tank drilled using the flue cover as a template.
  - III. When tank covers are involved, all tank covers are to be placed on the respective tanks in accordance with the assembly drawing to insure proper fit, as soon as the first tank section is completed. The purchaser is to be advised at that time to make an inspection of the first assembly so that any discrepancies can be detected and corrected.
  - IV. All duct work should be match-drilled with each adjoining section or sections.

### WELDING

- a. All joints over which rubber is to be applied are to be joined with a continuous solid weld.
- b. All welds over which rubber is to be applied must be smooth with no porosity, holes, high spots, lumps, pockets or undercuts. Proper peening and grinding are required in order to eliminate porosity, sharp edges and high spots sharp edges or high spots.
- c. Body seams are to be butt-welded with continuous solid weld throughout unless drawing or purchase order specifies lap weld. Body welds to be rubber covered must be ground flush - small hump allowed.
- d. Misalignment of plates and butt weld seams is not to exceed 25% of the plate thickness and in no case to exceed 1/8".
- e. Nozzles, pad flanges and manways shall be properly braced if necessary so as to prevent 'sinking' during the welding process. Maximum allowable tolerance - 3/16".
- f. Partitions, braces, supports or other attachments to be rubber covered are to be fitted flat against the adjacent surface and full welded from all sides. Any closed chamber, so created is to have a small air vent hole drilled to the chamber from an area not to be rubber covered, to prevent pressure buildup of enclosed air when heated.
- g. Interior corners to be rubber lined are to have a minimum radius of 3/8".
- h. Weld splatter must be removed entirely.
- i. In all cases, the fabricator shall assume responsibility for the strength of welds.
- j. All sharp edges and corners shall be ground to a smooth, with a contoured surface radius of 1/8" minimum.

### OUTLETS

The size, construction and location of outlets and openings shall be furnished in accordance with the drawing or detailed information. All flanges are to be parallel with or perpendicular to the vessel, so that the pipeline will leave the vessel surface at a right angle, unless otherwise specified.

### TESTS

- a. Where test pressure, working pressure or both are specified for a vessel, the fabricator shall hydrostatic test the vessel. An affidavit of the test is to be furnished when requested.
- b. Where certification of test is required by a licensed inspector, the standard test plate with necessary stamping and approval will be affixed to the exterior vessel surface by the fabricator.
- c. Vacuum tanks will be tested to the vacuum shown on the drawing or order when so specified. The method of test should be approved by the applicator.
- d. All tests by the fabricator may be observed by an applicator representative on request.

### INSPECTION

The applicator should reserve the right to inspect all metals at the fabricator's plant both during fabrication and on completion. Metals received from metal suppliers which do not conform with this specification may be returned to the supplier at his expense and shall constitute sufficient cause for rejection.



## SECTION 8: METAL FABRICATION



### IDENTIFICATION

- a. When so requested, metals are to be conspicuously identified on their exterior surface to show part or mark number.
- b. When the weight of a vessel exceeds 2,000 pounds, the weight is to be painted thereon in a conspicuous place.

### SHIPMENT

- a. Metals shall be loaded and secured for shipment in such a manner as to ensure delivery in first-class condition to the applicator. Cylindrical tanks with manholes shall be loaded with the manhole 45 degrees from the bottom. Open rectangular vessels are to be loaded with open end upward unless prohibited by lack of clearance.
- b. Nuts, washers and other auxiliary items called for on the purchase order or drawing shall be properly packaged or secured so as to ensure safe arrival at applicators factory or jobsite. These items to be properly identified with purchase order or drawing number.

**PREPARATION OF PLAIN END PIPE AND SLIP-ON FLANGES FOR RUBBER LINING**

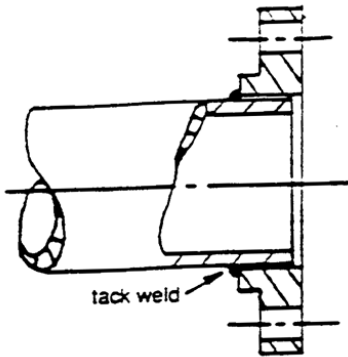

SIZES – 1-1/2" & Up in Mill Lengths Max & Short Pieces of 1-1/4" Pipe

Slip flange on pipe leaving a space for welding equal to the pipe wall thickness.

Tack weld flange to pipe, line up holes of second flange with first flange, then tack weld flange to pipe.

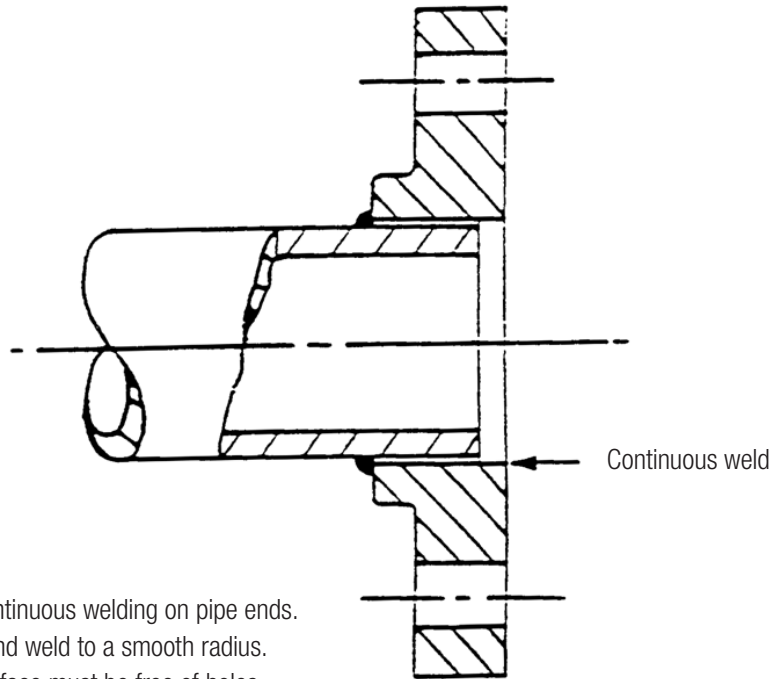

Continuous welding on pipe ends.  
Grind weld to a smooth radius.  
Surface must be free of holes.

PREPARATION OF PLAIN END PIPE AND SLIP-ON FLANGES FOR RUBBER LINING

TANK JOINTS

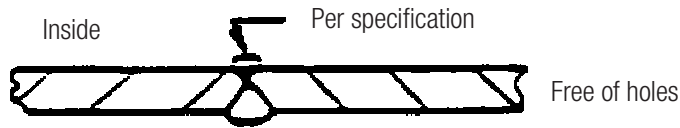

Butt Joint

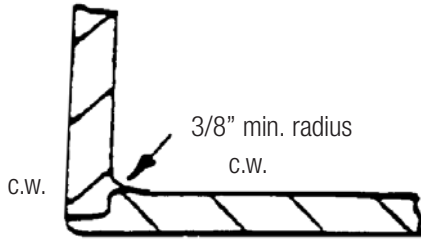

Preferred Corner Construction

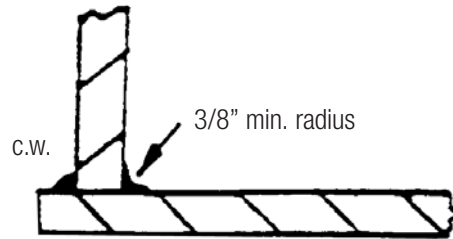

Acceptable Corner Construction

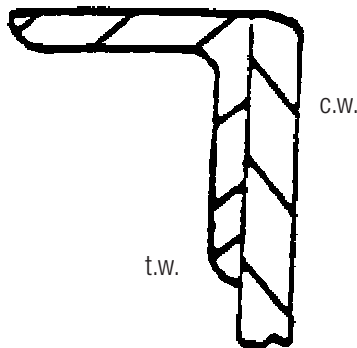

Curb Construction

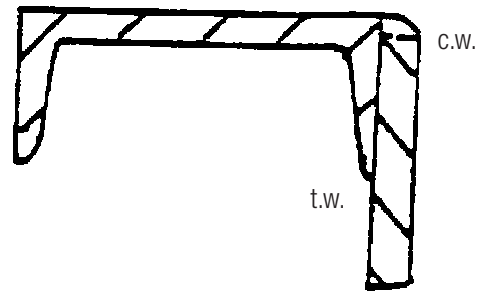

Curb Construction

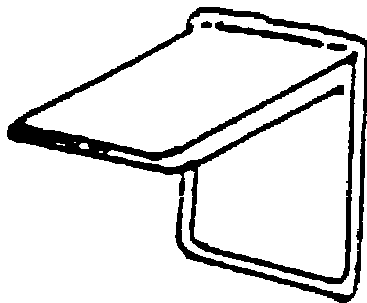

All welding to be covered must be continuous and per specification.

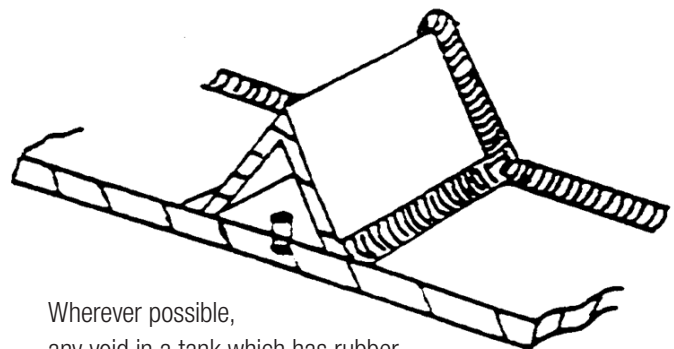

Whenever possible, any void in a tank which has rubber covering over any of its welds, vent holes should be drilled to relieve pressure build up during cure.



Riveted Joints

Vent Hole

Note: c.w. – continuous weld (all welds to be covered)  
t.w. – tack weld